

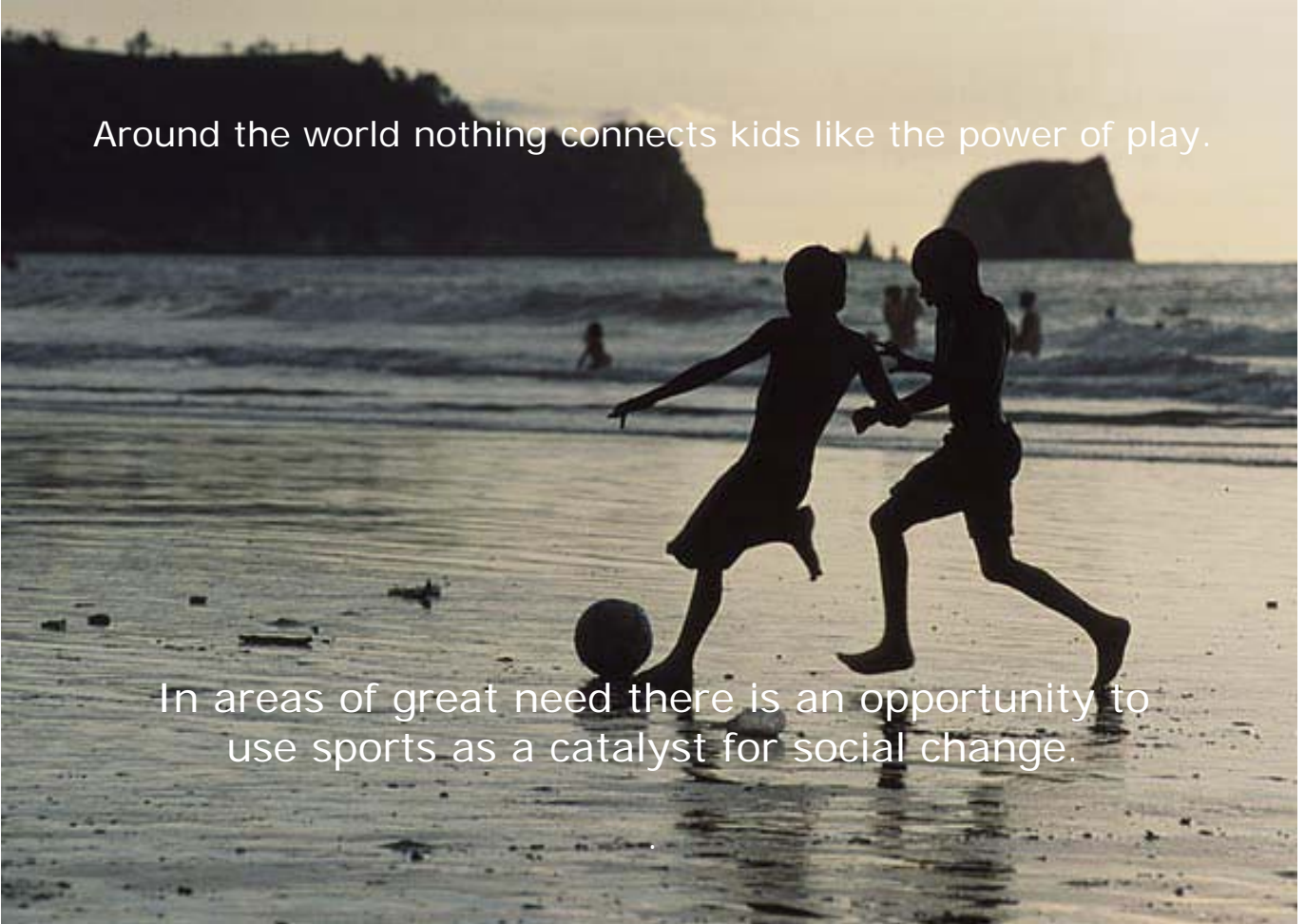

Around the world nothing connects kids like the power of play.



In areas of great need there is an opportunity to use sports as a catalyst for social change.

Where resources are scarce, we can create
Community access points to deliver vital services.

Let's create highly transportable and deployable play
spaces that are sustainable infrastructure nodes.

Let's create Sportables.



Sportables

Google SketchUp 3D Basecamp Competition

<http://www.openarchitecturenetwork.org/sportables>
challenge@openarchitecturenetwork.org

Designing Sportables: Mobile Demountable Sport Product Library & Play Facility

Need: Nothing connects kids like the power of play. In areas of great need are opportunities to use sports as a catalyst for social change. Where resources are scarce, products can be distributed to deliver vital services. In many parts of the world sporting activities, especially local and traditional sports, are being incorporated into a variety of programs geared toward helping youth address a broad range of issues affecting their lives.

By emphasizing a "team" approach, these programs help impart the skills needed by the next generation to overcome the many challenges faced by their countries, from poverty to HIV/AIDS, malnutrition to low educational access. The Sportables play area and product library aims to provide the youth in communities with limited resources the opportunity to play sports safely, securely, and frequently.

Challenge:

Transport yourself to Capao Redondo, a densely packed, but colorful, friendly and energetic settlement on the outskirts of Sao Paulo, Brazil. Here the youth run through the narrow alleys and small spaces mimicking the moves of football heroes like Ronaldo and Ronaldinho, but in bare feet. Open space is a premium, and not always available (i.e. market spaces)

Your challenge is to design a solution to create a highly demountable, portable sports product library, product development studio, and futsal (soccer) play area. This "pop-up" facility will be deployed to provide much needed (and desired) jerseys, shoes, and balls to communities that would welcome and use them to inspire change for youth of both genders. The design should comprise of a structure and construction mechanism that can unfurl to provide a space to rent sports gear as well as a safe space for youth to play, but must be re-packaged securely to protect the goods and equipment when the play area is not used or space is not available, or when it moves from one location to another.

Design Constraints:

Design Teams should consider some or all of the following:

- Each of these units must be assembled on site and delivered from the by various modes of transportation [on land and over water]
- When deployed, the design should provide safe places to play, secure means of delivering product (with incentives to return product at the end of play)
- When closed, the design should provide secure storage for all contents.
- Employ sustainable and/or local building materials and construction methods to realize their design. Materials should be reclaimed where possible.
- Develop mechanisms for off-grid, self sufficient sources of power for lights, communications (phone or internet) and water.
- Address issues of crowd control and security when products are distributed



Community and Economic Development by Design:

- An approach where youth in the neighborhood could build and maintain the facility without the need of government intervention. Address needs of girls and women in the community including empowerment and safety.
- Use factors to ensure equal access for girls and boys
- Develop ways that the products in the library can facilitate income-generating enterprises: an adjacent design workshop to develop clothing, shoe or other designs to sell, a complementary retail stand or revenue generating enterprise to sell/market popular designs
- Micro-business generation through production: Imagine processes that will allow library units to be self-maintained and operated and serve as development hubs for supporting and generating local social entrepreneurs.
- As most youth are either in school, or more often working, during the day teams must figure out a way to allow these facilities to operate in the late evening and early mornings.
- Use informal solutions to transform under-utilized public space on a temporary basis.
- Meeting space for large gatherings (to kick off games, hold community or educational events)

Futsal Field

- Dimensions 15m x 28m (49ft x 91ft)
- Surface: Use location surface, but provide demarcation for the field dimensions

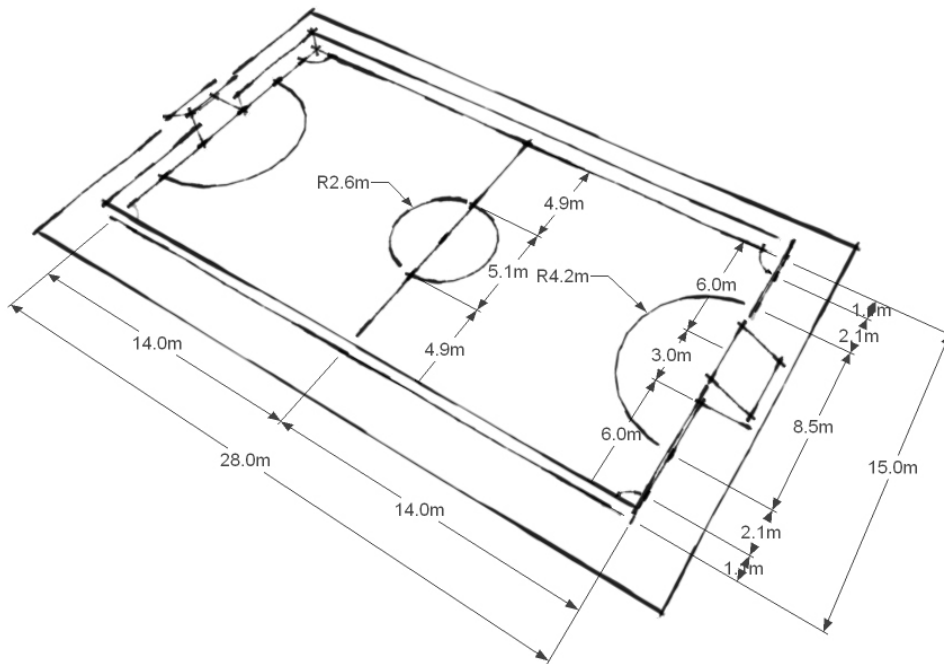

Sports Products/Equipment

- Shirts
- Shorts/Pants
- Shoes
- Balls
- Goals + goal posts



Library Lending Components:

- Desk, chair, lamp
- Different locks with 3 keys
- Scissors, knives, markers, label makers, stamps
- Empty boxes
- Cleaning materials (sprays, polish, and so on)

Registration Requirements:

Register for and maintain an account on the Open Architecture Network:
<http://www.openarchitecturenetwork.org/register>

Submission Requirements:

- All team members should register on the Open Architecture Network (username/pwd)
- Team Leader signs up for a competition entry (log-in before signing up), and may invite any other team members (by username or email)
- Submit entry on the Open Architecture Network
 - Project Title
 - Project statement (200 word minimum)
 - Minimum 3 images of the 3-d model
 - Formats: .jpg, .png, .gif
 - Dimensions: 3000px x 2000px (pref. 10" x 15" @ 200 dpi)
 - Native Sketchup (.skp) file
- Submit model on the Google Sketchup 3D Warehouse

Jury

John Bacus, Google Sketchup Product Manager
Cameron Sinclair, Co-Founder & Eternal Optimist, Architecture for Humanity
Aykan Gultan, Nike Social Innovation
Possibly 1-2 more jury members, TBD

Schedule

June 11	Competition announced at Google Sketchup 3D Basecamp
June 12	Registration at Info Table
June 13	Competition Morning charette 9:15-12:00
	Winners of morning charette announced at closing session
June 14	Competition opened to the Google Sketchup community at large
June 30	Competition ends
July 1-3	Jurying takes place
July 3	First place, second place, third place winners announced

Prizes

Full Competition Prizes

First Place	\$1000
Second Place	\$500
Third Place	\$250

If you have any questions regarding the Open Architecture Network or the Sportables challenge, please contact us at challenge@openarchitecturenetwork.org



Rules

The purpose of the Google Sketchup Sportables Challenge is to improve access to sports in support of community building and social change throughout the world. To that end, we ask that all entrants read and agree to the rules before entering the competition. The rules are intended to make it possible for Architecture for Humanity to share all of designs submitted to the competition with those who could benefit most from them and—ultimately—to build one or more winning designs.

In submitting an entry to the Google Sketchup Sportables Challenge, all participants agree to comply with the rules and terms of entry below.

Eligibility

The Google Sketchup Sportables Challenge is an open, international competition. Employees and family members of employees of Architecture for Humanity and Google are precluded from participating in the competition, but there are no other restrictions on who can enter. Architects, design professionals, non-professionals, professionals in other fields and students of all ages are encouraged to participate.

In order to enter the competition, entrants must register for the Open Architecture Network. Participants may participate in multiple teams. For jurying purposes, each design is considered as a separate entry. Multiple designs will not be considered as a single entry.

Period of Submission

Entrants are invited to develop their design throughout the submission period. Once the submission period has ended they will not be permitted to make changes to their entry until the jurying has concluded at which time entrants will regain access to their project and may continue to develop their design. Entries that are late, illegible, incomplete, misdirected or incompletely received will not be eligible.

The period of submission for the Google Sketchup Sportables Challenge is June 13, 2008 to June 30, 2007. The competition organizers reserve the right to delay or extend the period of submission.

Anonymity and Design Credit

All files uploaded must be submitted without any markings that will identify team members in order to facilitate fair jurying of the competition. Building Plans, Building Elevations, Site Plans, Renderings and any other files submitted for consideration should not include title blocks or any other identifying information. Failure to comply with this rule will lead to disqualification.

This does not apply to the Project Details or "Edit Settings" area of each entry, which must be completed in full and must include the names and roles of all team members. Please note: Information entered in the Project Details or Project Settings area will be used to give proper credit to design team members.

Ownership and Copyright

By entering the competition, entrants agree to a) post entry materials to the Open



Architecture Network and to the Terms of Use of the Open Architecture Network; b) to license all materials submitted under the Creative Commons Developing Nations license and to adhere to the terms of that license.

Entrants shall own all design concepts, drawings, images, renderings, sketches, photographs, models, and/or text, documents, information or other materials submitted in association with the competition provided. However, the entrant hereby grants Architecture for Humanity and its designees perpetual, free, unrestricted use of the submission materials in fulfillment of its charitable purposes, including its annual report, its websites and in communications with volunteers, funders and the media and all other purposes specified in these Rules. Such use is expressly not directed toward commercial advantage or private monetary compensation.

Notwithstanding AFH's rights as a Licensor, competition entrants shall retain full rights to use the documents in other projects for commercial and for-profit purposes. By entering this competition entrants warrant that all materials submitted by them are their own, that nothing in the submission of these materials will infringe the copyright or any other right of any person and that they have full authority to submit the materials for such purposes.

Exhibition and Publication

The organizers will exhibit selected entries to the Google Sketchup Sportables Challenge during and after the competition. The results of the competition may be presented online, in galleries or other venues, or in a printed publication and all entries will be available to be viewed on the Open Architecture Network. Selected and Finalist entrants may be asked to build scale models representing their design and provide printed presentation boards for exhibition purposes.

In any exhibition, publication, or website, the organizers will make every effort to properly credit the appropriate competitors. Architecture for Humanity and its designees reserve the right to utilize materials submitted by entrants in any publication or promotional endeavor in perpetuity and free of charge (See "Ownership and Copyright").

Disputes

The jury has the sole authority and responsibility to recommend winners at the end of the competition. The organizers reserve the right to make a final decision regarding the winning scheme and any funding that may be made available for the development or implementation of designs entered into the competition. The competition administrators decisions in connection with all matters concerning the competition shall be final and binding.

Limitation of Liability

By entering the competition, all entrants and team members agree to indemnify, defend and hold Architect for Humanity including its chartered units, and its governors, directors, officers, employees, agents, partners, funders, sponsors and volunteers from and against any and all suits, claims, demands, liabilities, damages, costs and expenses (reasonable attorneys' fees) arising out of or relating in any way to services it provides in connection with this agreement.

If you have any questions about the rules stipulated above, please do not hesitate to contact the competition administrators.